

HANDENDROGER SYNOX

850900, 850912, 850914

WWW.LOGGERE.COM

Beschrijving:

Elektronische handdroger voor wandmontage.
 Zeer krachtige elektronische motor,
 geactiveerd door infraroodsensor.
 Met blauw LED-display.
 Incl. bevestigingsmateriaal

Technische details:

- Automatische uitschakeling na 2 sec.
- Stroomvoorziening: AC 220 V
- Ingangsvermogen: 1410W
- Vermogen motor: 600W
- Verwarmingsvermogen: 800W
- Luchtsnelheid: 100m/s
- Motor: Seriemotor
- Type sensor: Automatische detectie
- Geluidsniveau: < 60dB(A)
- Automatisch verwarmen - $\leq 25 \pm 2^{\circ}C$

Aanbevolen installatiehoogte: 1200mm,
 voor gehandicapten: 970mm
 voor kinderen: 900mm

Specificaties:

- **Kleur:**
RVS/Zwart/Wit
- **Materiaal:**
Geborsteld Roestvrij staal, 1,2mm dik
- **Afmetingen:**
B 215 x D 138 x H 190 mm

850900 - RVS



850912 - Zwart



850914 - Wit

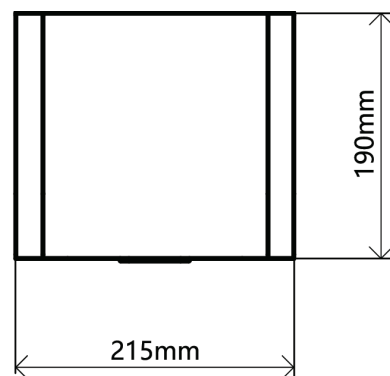
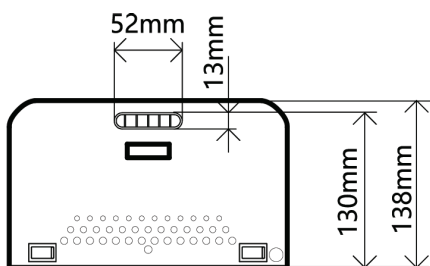
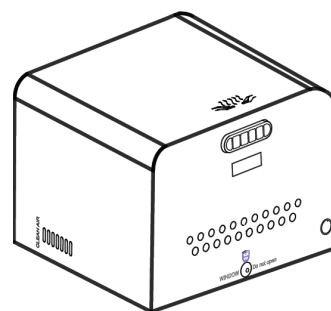

Verdere Loggere productaanbevelingen



Sanitair

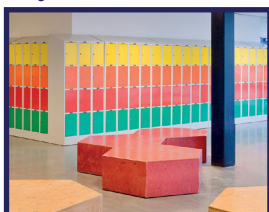

Lockers en kastsystemen



Sanitaire wanden



Garderobesystemen



Kantoorunits